



MACH[®] 3

Coin sorter/counter/packager

Compact coin sorter/counter/packager suitable for tabletop or portable applications

MACH[®] 3

Coin sorter/counter/packager

The **MACH 3** is a versatile, cost efficient, compact coin sorter/counter/packager that simplifies coin processing for any business that currently counts, sorts or wraps coin by hand.

Ultimate in versatility

MACH 3 sorting containers can be configured to create a truly customised solution for each application. Processing only a few coins of one denomination? Use a standard drawer for coin capture. Processing large amounts of other denominations? Use a bagging attachment to limit the number of times a user need stop the count process. Coin drawers (two sizes), coin bags, or packaging kits (US/Canada) can be used in any combination to optimise throughput.

Compact size

The **MACH 3** is equally at home sitting on the counter of a small bank branch, retail cash office, or, using the built-in carrying handle, transported from location to location to process vending or ticket machine contents. Counter space at a premium? The **MACH 3** easily stores under the counter and out of the way until it's needed.

Ease of use

User selectable bag stops as well as batch and grand totals are accessed via a direct access keypad. A two-line alphanumeric LCD display conveys operational messages at a glance. With few moving parts and full coin path access, the **MACH 3** is easy to use and maintain.

Configuration options

In addition to the various coin capture options, the **MACH 3** can also be configured with RS232 serial ports, audit trail printer, remote display, carrying bag/cover, and magnet kit for the removal of ferrous slugs and debris.

As the cash solutions experts, over 5000 retail banks already trust De La Rue's solutions and expertise. The global market leader in Branch Teller Automation solutions, De La Rue's unrivalled knowledge of the complexities of cash management enables us to understand individual customer requirements, to propose a quantified value proposition and compelling business case to help achieve commercial, operational and financial goals.

Technical specification

Coin size range

Diameter: 15.0mm to 32.4mm

Thickness: 1.0mm to 3.0mm

Differential: 0.5mm minimum

Tilting inspection pan capacity

Up to 1000 coins

Coin feed (hopper) capacity

Up to 600 coins

Processing speed

Up to 1500 coins per minute

Sorting capability

Up to 6 different denominations

Bag stops

Three selectable bag stops per denomination

Security features

Battery back up in the event of power failure

Power supply

90V - 264 AC, 50/60 Hz

Options

Tokens, non-round coin, etc. subject to review

Standard coin drawers – up to 500 coins

Mega coin drawers – up to 1000 coins

Tabletop bagging attachment

Tabletop bagging pedestal

Coin tubing kits (US/Canada only)

Cash till sorting kit (US/Canada only)

Inspection pan magnet

RS232 (2) serial interface ports

Printer – 24 column

Remote batch total display

Soft-sided carrying bag/machine cover

Dimensions

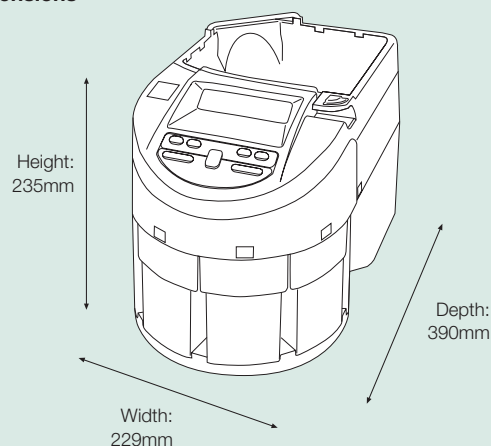

Weight: 7.6kg

Compact size
Up to 1500 coins per minute
Two levels of totals
Tabletop or portable configurations



BS EN ISO 9001
FM 689



This leaflet is for general guidance only. De La Rue International Limited is pleased to give detailed specifications of its products in this leaflet. As the company's products and services are continually being developed it is important for customers to check that the information contained herein includes the latest particulars. This document is not part of a contract or licence save insofar as may be expressly agreed.

MACH is a registered trademark of De La Rue International Limited.

© De La Rue International Limited 2006

DE LA RUE CASH SYSTEMS

De La Rue House
Jays Close
Viabes
Basingstoke
RG22 4BS
www.delarue.com



DeLaRue

MACH 3 DLR-BTA-023 April 2006